

NUMBER  
C-1775059

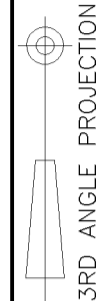

METRIC

NOTES:

ITEM	PARTS NAME	MATERIAL	FINISH/REMARK
A	HOUSING	TERMOPLASTIC HIGH TEMP	UL 94V-0, BLACK
B	SHELL	STAINLESS	NON-PLATING
C	HOLDDOWN CONTACT	PHOSHPOR BRONZE	100μ" MIN. BRIGHT-TIN PLATING ON SOLDER TAIL AREA 50μ" MIN. NICKEL UPDERPLATING OVERALL
D	CAM PIN	STAINLESS	NON-PLATING
E	CARD LOCK	PHOSHPOR BRONZE	100μ" MIN. TIN PLATING 50μ" MIN. NICKEL UPDERPLATING OVERALL
F	SLIDER CAM	TERMOPLASTIC HIGH TEMP	UL 94V-0, BLACK
G	SPRING	SWP	50μ" MIN. NICKEL UPDERPLATING OVERALL
H	CONTACT-SD	PHOSHPOR BRONZE	GOLD (SEE TABLE) PLATING ON CONTACT AREA 100μ" MIN. TIN PLATING ON SOLDER TAILS 50μ" MIN. NICKEL UPDERPLATING OVERALL
I	PROTECT CONTACT		
J	PROTECT CONTACT AND DETECT CONTACT-SWITCH		
K	DETECT CONTACT		
L	FAKE CARD	LCP	BLACK

3. APPLIED TO IR SOLDERING PROCESS
4. NET WEIGHT: 10 GRAMS.
5. OTHERS:
  - 5.1 WHEN DELIVERING, THE PSH/PUSH MECHANISM IS IN THE STATE OF THE UNLOCK.  
(CARD DASHING OUT POSITION)
  - 5.2 CARD READ ONLY BY THE TIME THE CARD DETECTION SWITCH WORKS.
  - 5.3 OPEN AND CLOSE OF EACH SWITCH.

CARD INSERTION STATUS	WRITE PROTECT SWITCH		DETECT SWITCH
	WRITE PROTECT POSITION	WRITE ENABLE POSITION	
CARD UNINSERTION	OPEN	OPEN	OPEN
CARD HALF INSERTION	COLSE	COLSE	OPEN
CARD INSERTION	OPEN	COLSE	COLSE

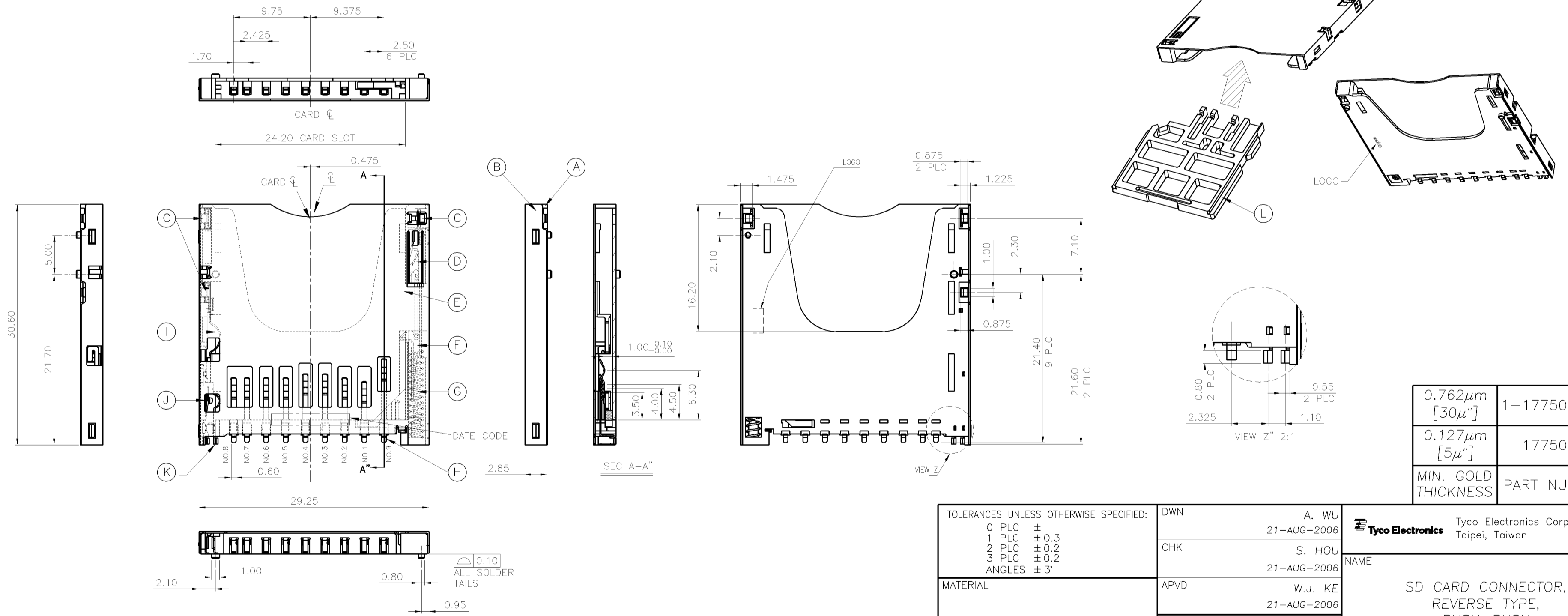

THIS INFORMATION IS CONFIDENTIAL AND IS DISCLOSED TO YOU ON CONDITION THAT NO FURTHER DISCLOSURE IS MADE BY YOU TO OTHER THAN AMP PERSONNEL WITHOUT WRITTEN AUTHORIZATION FROM AMP (TAIWAN) LTD. DIMENSIONS IN MILLIMETERS. DO NOT SCALE. PRINT.

PRINT  
DW

B	ADD P/N -11	ECR-08-027038	AW	27OCT
LTR	REVISION RECORD	ECN	DWN	2008
			CHK	DATE

TOLERANCES UNLESS OTHERWISE SPECIFIED:	DWN	A. WU
0 PLC ±		21-AUG-2006
1 PLC ±0.3	CHK	S. HOU
2 PLC ±0.2		21-AUG-2006
3 PLC ±0.2	APVD	W.J. KE
ANGLES ±3°		21-AUG-2006
MATERIAL	SEE NOTE	
FINISH	SEE NOTE	

PRODUCT SPEC	108-57504
QUALIFICATION TEST REPOERT	501-57578
WEIGHT	SEE NOTE

Tyco Electronics Corporation Taipei, Taiwan			
NAME			
SD CARD CONNECTOR, REVERSE TYPE, PUSH-PUSH			
LOC	SIZE	DRAWING NO	REV
DW	A <sub>3</sub>	C-1775059	B
SCALE	SHEET		
--	1 OF 5		

THIS INFORMATION IS CONFIDENTIAL AND IS DISCLOSED TO YOU ON CONDITION THAT NO FURTHER DISCLOSURE IS MADE BY YOU TO OTHER THAN AMP PERSONNEL WITHOUT WRITTEN AUTHORIZATION FROM AMP (TAIWAN) LTD.

PRINT DIST  
DW

METRIC

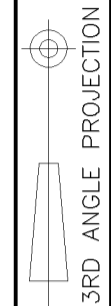

NUMBER  
C-1775059

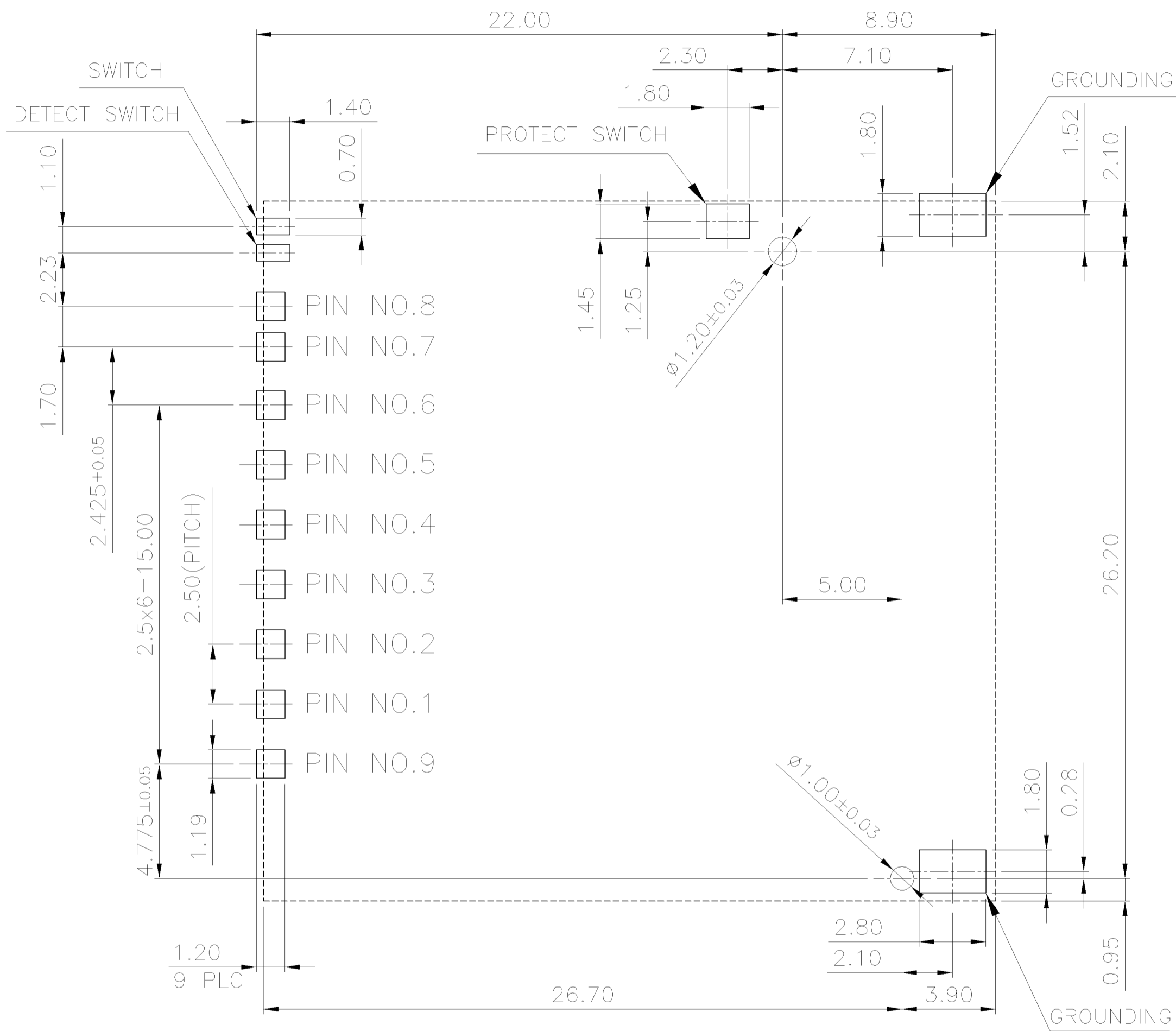

(FOR P/N: 1775059-1 & 1-1775059-1)

PIN DEFINE

PAD NO.	MEMORY CARD
SD-01	SD-CD/DAT3(SD-01)
SD-02	SD-CMD(SD-02)
SD-03	SD-VSS(SD-03)
SD-04	SD-VDD(SD-04)
SD-05	SD-CLK(SD-05)
SD-06	SD-VSS(SD-06)
SD-07	SD-DAT0(SD-07)
SD-08	SD-DAT1(SD-08)
SD-09	SD-DAT2(SD-09)

RECOMMENDED PCB LAYOUT  
PCB TOLERANCE: ±0.05

SEE SHEET 1	ECN	DWN	CHK	DATE
LTR	REVISION RECORD			

TOLERANCES UNLESS OTHERWISE SPECIFIED:		DWN		A. WU		Tyco Electronics Corporation	
0 PLC	±	21-AUG-2006		S. HOU		Tyco Electronics Corporation	
1 PLC	±	21-AUG-2006		W.J. KE		Taipei, Taiwan	
2 PLC	±	21-AUG-2006		APVD		NAME	
3 PLC	±	21-AUG-2006		PRODUCT SPEC		SD CARD CONNECTOR, REVERSE TYPE, PUSH-PUSH	
ANGLES	±	21-AUG-2006		QUALIFICATION TEST REPORT		LOC	SIZE
		21-AUG-2006		---		DW	A <sub>3</sub>
		21-AUG-2006		WEIGHT		DRAWING NO	REV
		21-AUG-2006		---		C-1775059	B
		21-AUG-2006		SCALE		SHEET	
		21-AUG-2006		---		2 OF 5	

NUMBER  
C-1775059

METRIC  
3RD ANGLE PROJECTION

METRIC

THIS INFORMATION IS CONFIDENTIAL AND IS DISCLOSED TO YOU ON CONDITION THAT NO FURTHER DISCLOSURE IS MADE BY YOU TO OTHER THAN AMP PERSONNEL WITHOUT WRITTEN AUTHORIZATION FROM AMP (TAIWAN) LTD. DIMENSIONS IN MILLIMETERS. DO NOT SCALE PRINT.

PRINT  
DW

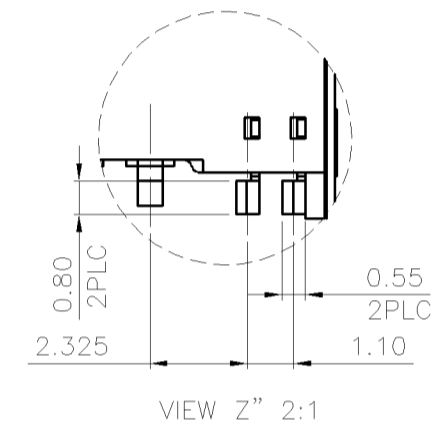
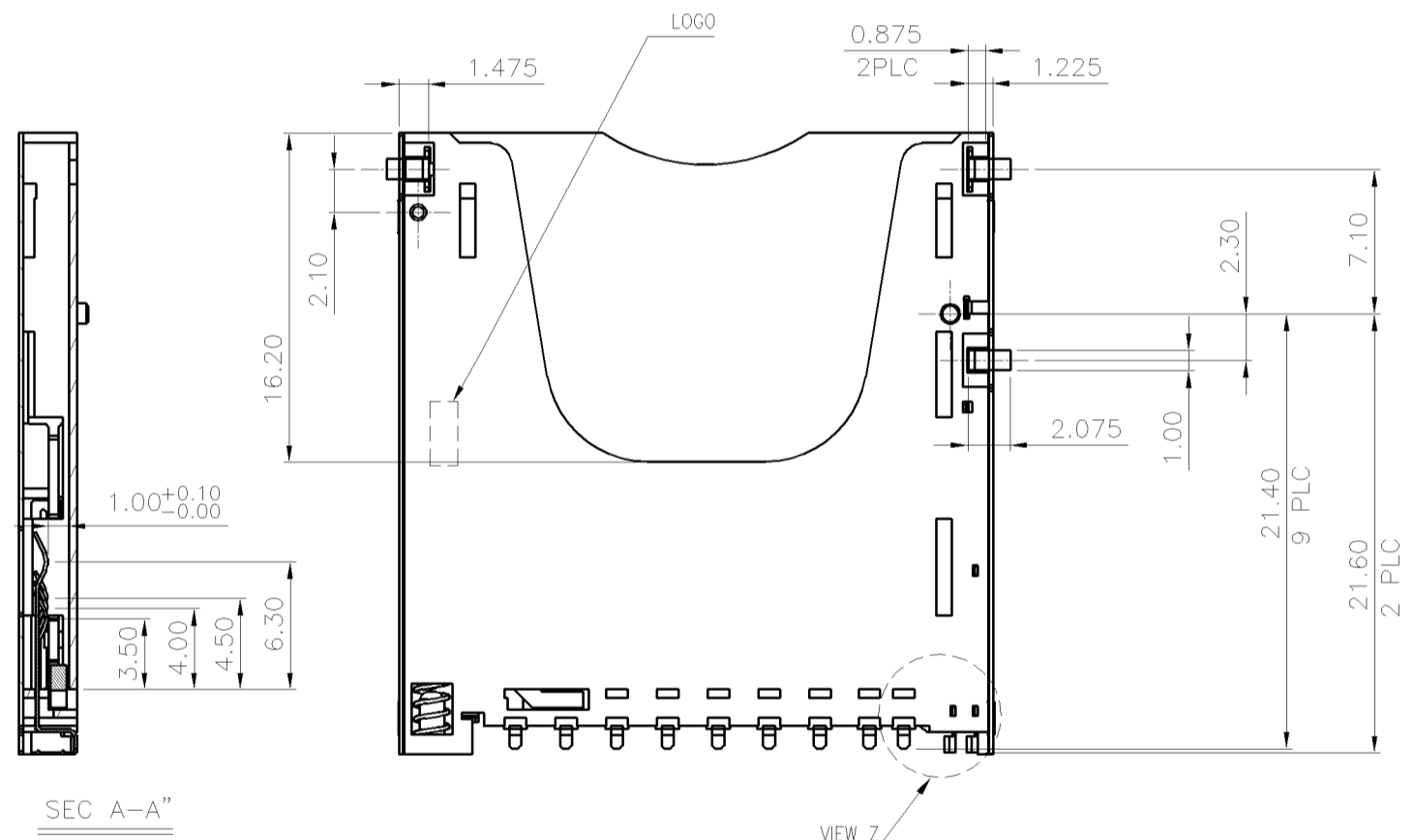
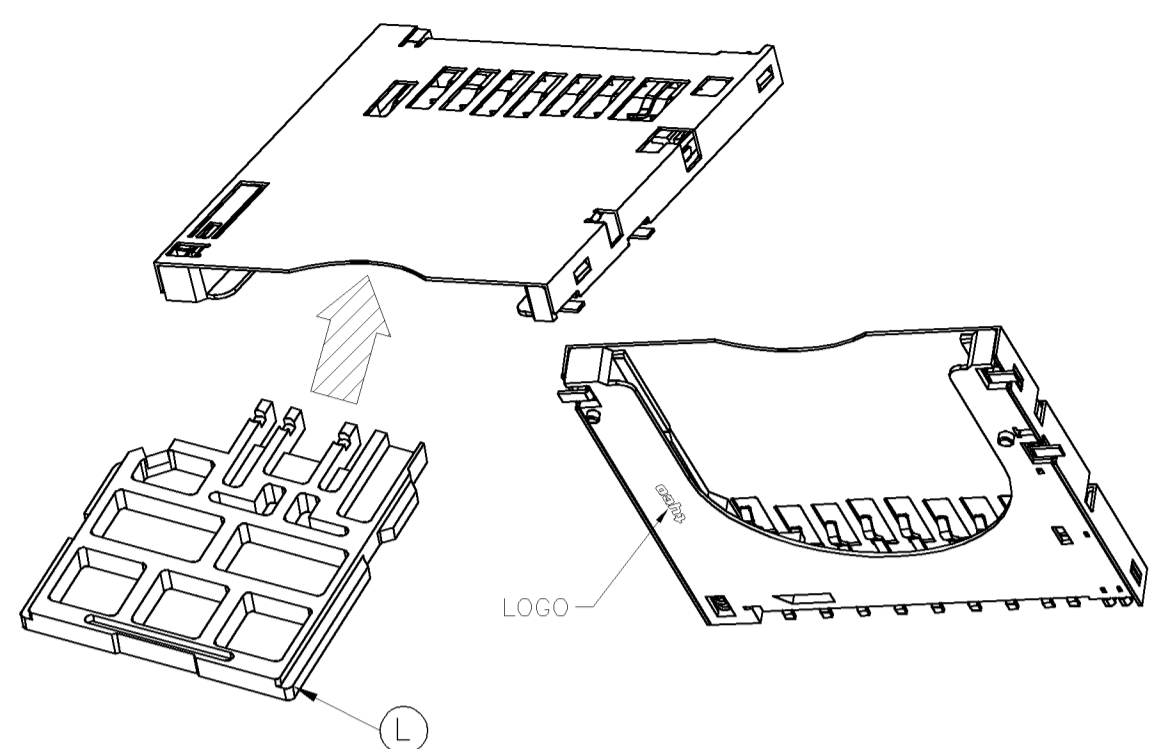
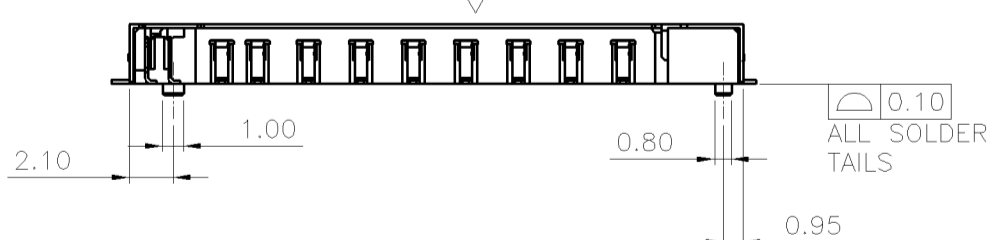
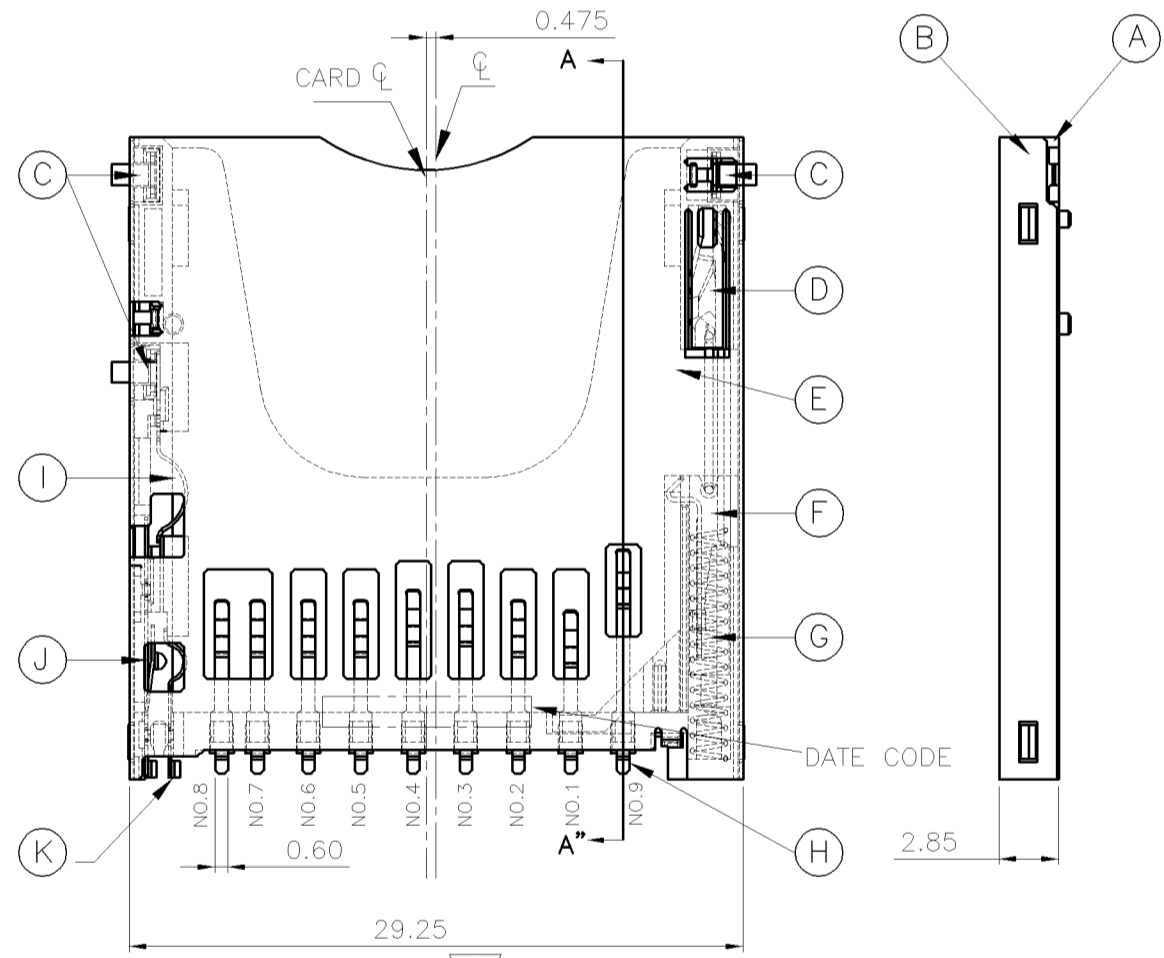
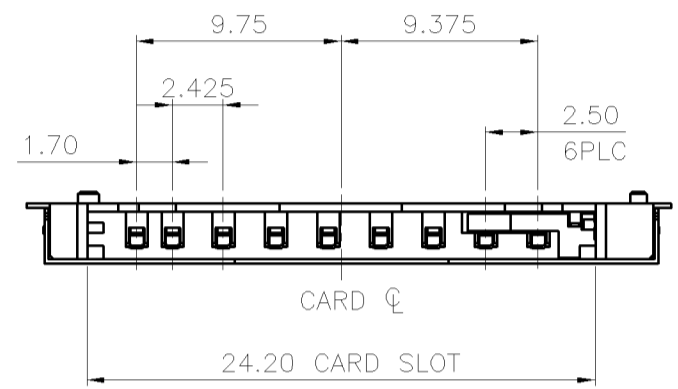
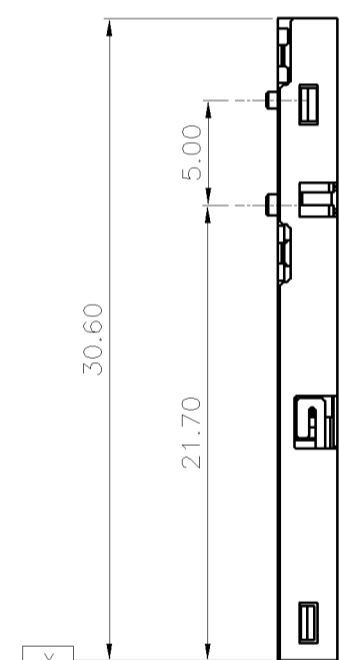

0.127μm [5μ"]	1775059-2
MIN. GOLD THICKNESS	PART NUMBER

TOLERANCES UNLESS OTHERWISE SPECIFIED: 0 PLC ± 1 PLC ±0.3 2 PLC ±0.2 3 PLC ±0.2 ANGLES ±3°	DWN A. WU 21-AUG-2006
MATERIAL SEE SHEET 1	CHK S. HOU 21-AUG-2006
FINISH SEE SHEET 1	APVD W.J. KE 21-AUG-2006
WEIGHT 10 GRAM	PRODUCT SPEC 108-57504
	QUALIFICATION TEST REPORT 501-57578

Tyco Electronics Corporation Taipei, Taiwan			
NAME SD CARD CONNECTOR, REVERSE TYPE, PUSH-PUSH			
LOC DW	SIZE A <sub>3</sub>	DRAWING NO C-1775059	REV B
SCALE --		SHEET 3 OF 5	

SEE SHEET 1			
LTR	REVISION RECORD	ECN	DWN/CHK/DATE

THIS INFORMATION IS CONFIDENTIAL AND IS DISCLOSED TO YOU ON CONDITION THAT NO FURTHER DISCLOSURE IS MADE BY YOU TO OTHER THAN AMP PERSONNEL WITHOUT WRITTEN AUTHORIZATION FROM AMP (TAIWAN) LTD.

PRINT DIST  
DW

METRIC

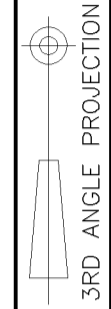

NUMBER  
C-1775059

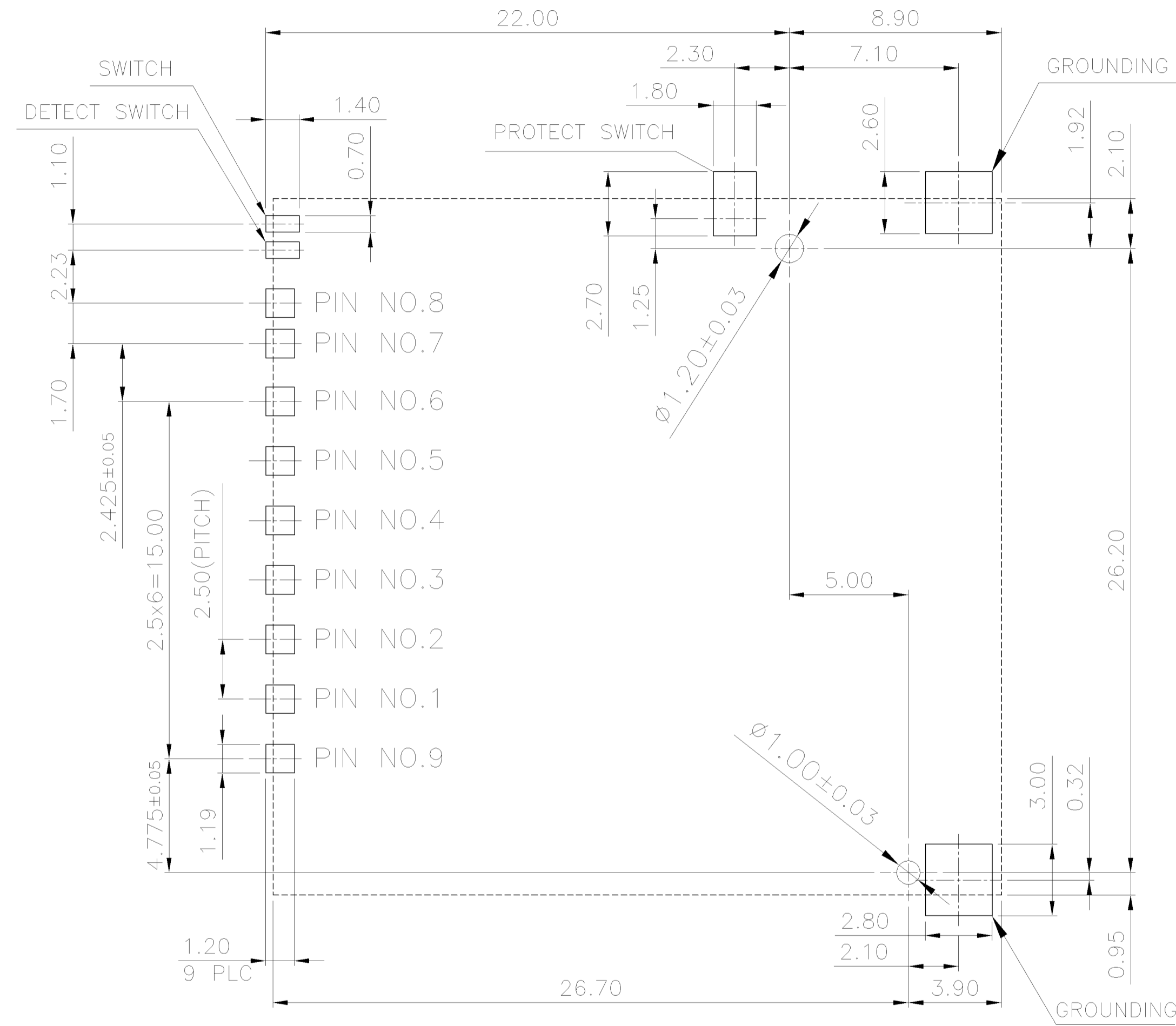

(FOR P/N 1775059-2)

PIN DEFINE

PAD NO.	MEMORY CARD
SD-01	SD-CD/DAT3(SD-01)
SD-02	SD-CMD(SD-02)
SD-03	SD-VSS(SD-03)
SD-04	SD-VDD(SD-04)
SD-05	SD-CLK(SD-05)
SD-06	SD-VSS(SD-06)
SD-07	SD-DAT0(SD-07)
SD-08	SD-DAT1(SD-08)
SD-09	SD-DAT2(SD-09)

RECOMMENDED PCB LAYOUT  
PCB TOLERANCE: ±0.05

SEE SHEET 1	ECN	DWN	CHK	DATE
LTR	REVISION RECORD			

TOLERANCES UNLESS OTHERWISE SPECIFIED:		DWN		A. WU		Tyco Electronics		Tyco Electronics Corporation	
0 PLC ±		21-AUG-2006		S. HOU		NAME		SD CARD CONNECTOR,	
1 PLC ±		21-AUG-2006		W.J. KE		REVERSE TYPE,		PUSH-PUSH	
2 PLC ±		21-AUG-2006		---		LOC		REV	
3 PLC ±		---		---		DW		A <sub>3</sub>	
ANGLES ±		---		---		SCALE		SHEET	
MATERIAL		APVD		---		DRAWING NO		C-1775059	
-		---		---		SCALE		4 OF 5	
FINISH		WEIGHT		---		---		---	
-		---		---		---		---	

NUMBER  
C-1775059

3RD ANGLE PROJECTION

METRIC

THIS INFORMATION IS CONFIDENTIAL AND IS DISCLOSED TO YOU ON CONDITION THAT NO FURTHER DISCLOSURE IS MADE BY YOU TO OTHER THAN AMP PERSONNEL WITHOUT WRITTEN AUTHORIZATION FROM AMP (TAIWAN) LTD.

PRINT DIST  
DW

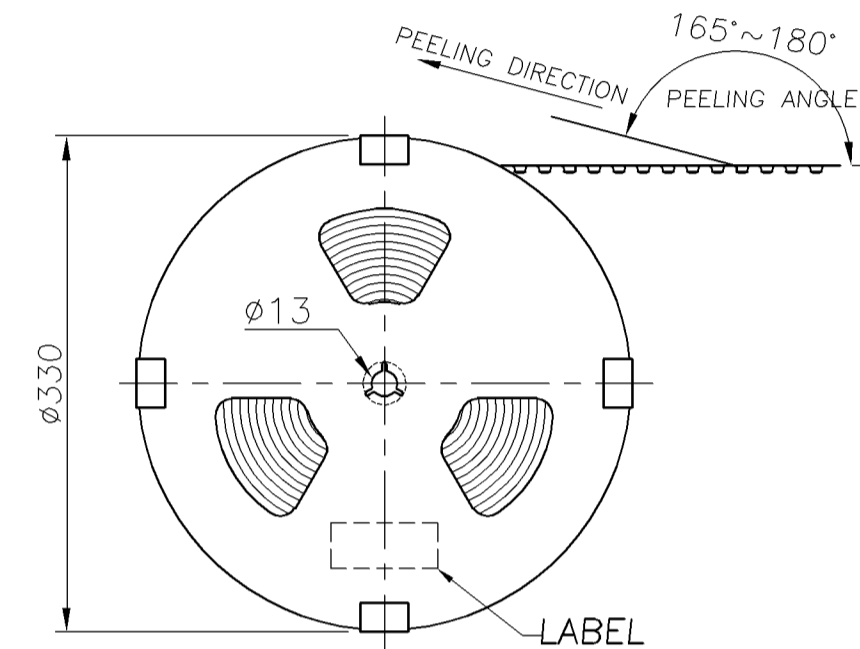
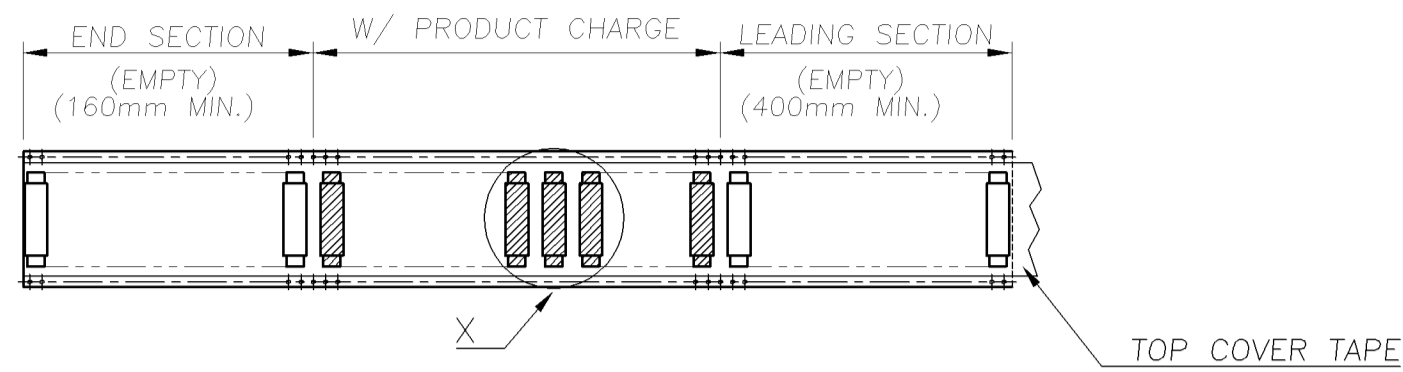
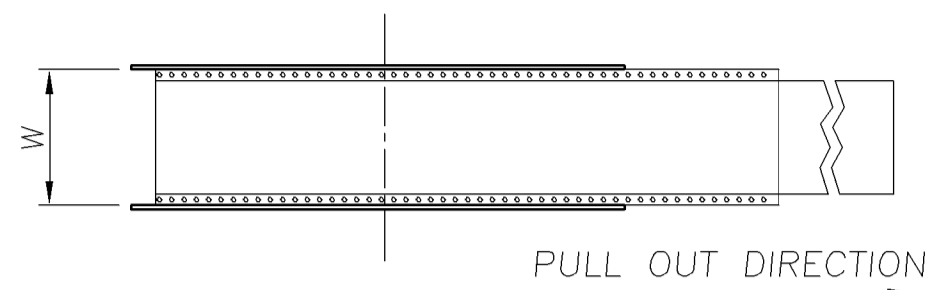

USER DIRECTION OF UNREELING

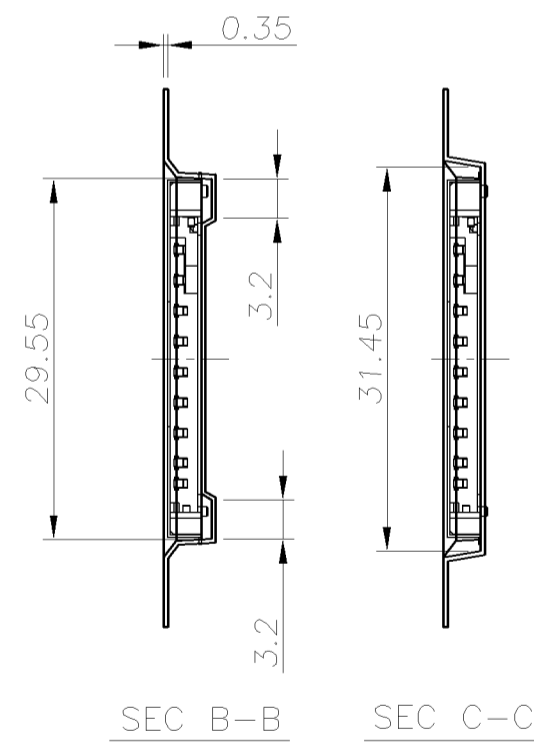
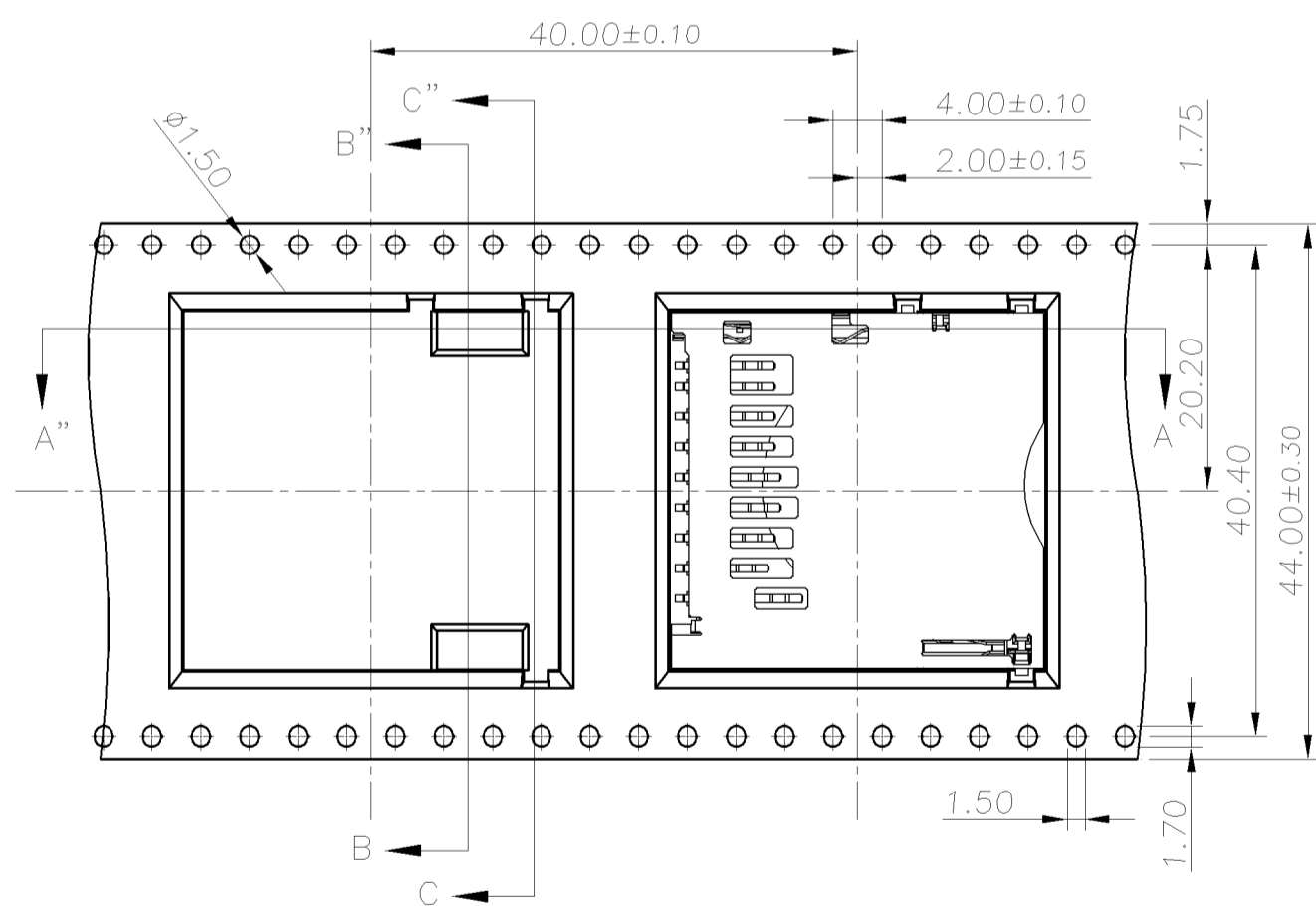

DETAIL X

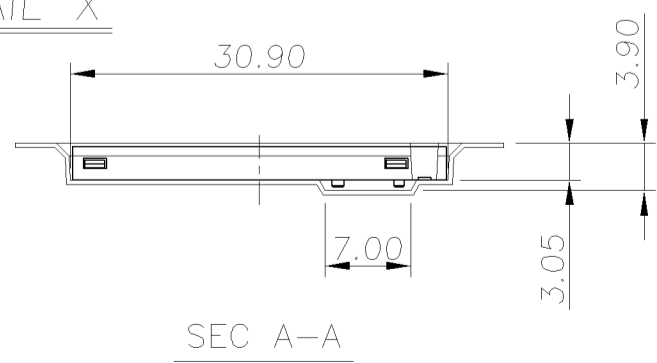

NOTES:

1. MATERIAL:
  - 1.1 EMBOSSED CARRIER: PS.
  - 1.2 COVER TAPE: PS.
  - 1.3 SHIPPING BOX: CORRUGATED FIBER.
2. DIMENSION:
  - 2.1 REEL: W= 44.5
  - 2.2 SHIPPING BOX: L=350, W=350, H=300.
3. QUANTITY:
  - 3.1 PRIMARY PACKING: 350 PCS/REEL.
  - 3.2 SECONDARY PACKING: 5 REELS/BOX (1,750 PCS).
4. WEIGHT:
  - 4.2 NET WEIGHT: 1.1 KG/REEL, 5.54 KG/BOX.
  - 4.1 GROSS WEIGHT: 1.81 KG/REEL, 9.79 KG/BOX.
5. PEELING RESISTANCE: 40 ~ 60 gf.
6. PEELING SPEED: 300 mm/minutes.

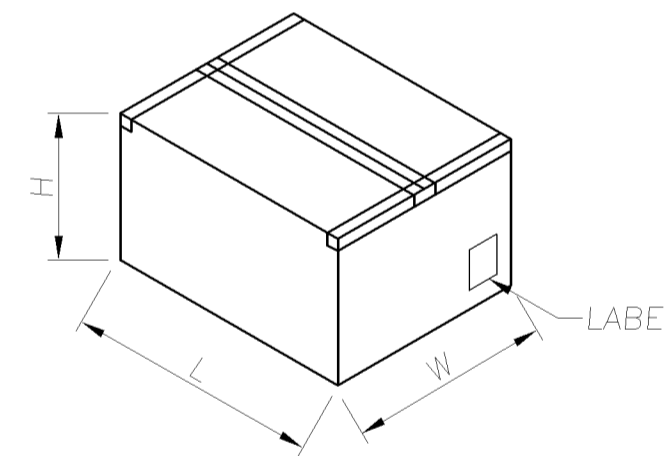
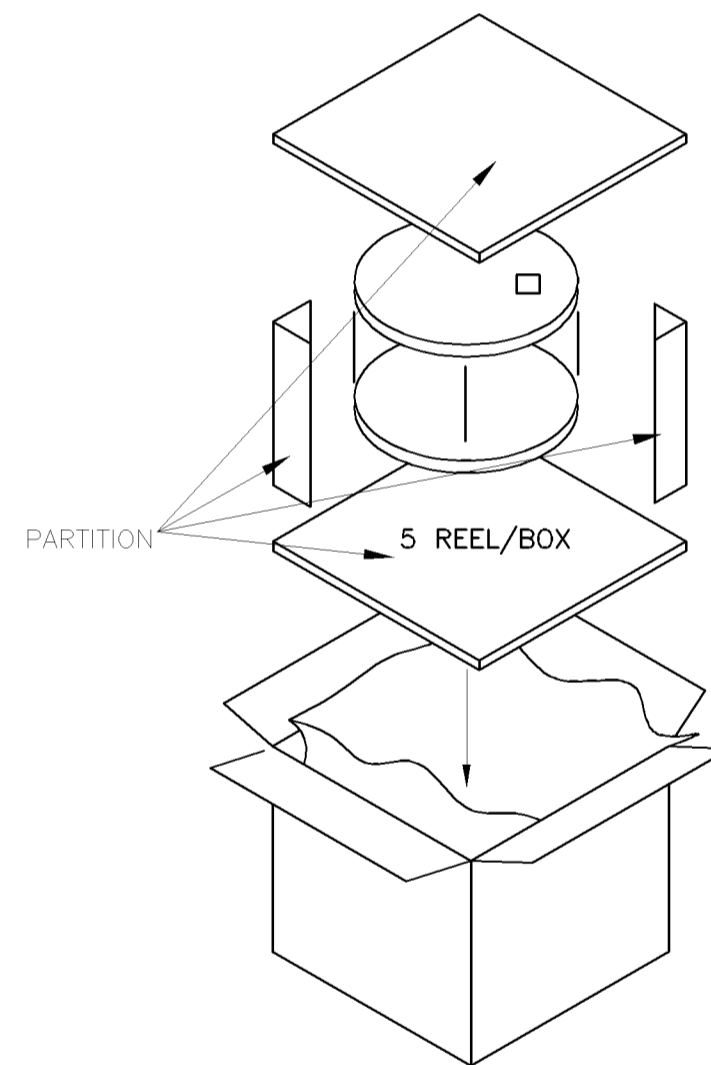

TOLERANCES UNLESS OTHERWISE SPECIFIED: 0 PLC ± 1 PLC ±0.2 2 PLC ±0.15 3 PLC ± ANGLES ±3°		DWN A. WU 21-AUG-2006	Tyco Electronics Tyco Electronics Corporation Taipei, Taiwan	
MATERIAL -		CHK S. HOU 21-AUG-2006	NAME SD CARD CONNECTOR, REVERSE TYPE, PUSH-PUSH	
FINISH -		APVD W.J. KE 21-AUG-2006	LOC DW	SIZE A <sub>3</sub>
PRODUCT SPEC --		APPLICATION SPEC --	DRAWING NO C-1775059	REV B
WEIGHT --		SCALE --	SHEET 5 OF 5	

SEE SHEET 1	REVISION RECORD	ECN	DWN CHK	DATE
-------------	-----------------	-----	------------	------